



Mining Series
P110V

Specially built telescopic platform for underground work
mounted on Dodge Ram



Standard equipment



Extra equipment/Options



The range of available options depends on the vehicle.

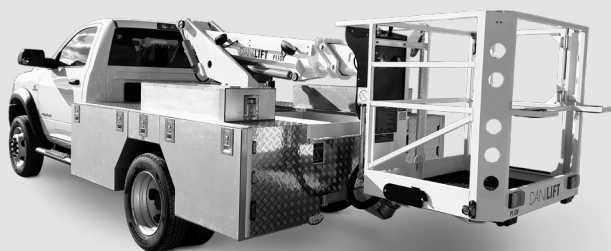

Technical specifications*

Max. working height:	9.1 m
Max. horizontal outreach:	5.7 m
Cage load capacity:	230 kg
Total weight:	8250 kg
Platform rotation:	2x55°
Safe working angle:	2°/5°
Isolation:	1000V

* Exact specifications vary based on the individual build and chosen options.

Description

The P110V mounted on Dodge Ram is a truly unique Danilift product.

This platform is one-of-a-kind. It is specially developed for underground work, with a total weight of 8.25 tons. This platform has no outriggers, but a tilting device instead which ensures easy movement. An ultrasonic sensor protects the operator while working underground, and a protective disc prevents stones from blocking the tyres.

Additional specifications:

Total weight 8.25 tons. 110° movable cage boom. Tilting device. Galvanized parts. 4-wheel brake. Electronic cabin protection. Protective disc that prevents stones from blocking tyres. Home function. Electric/hydraulic control. Various warning lights.

Diagrams

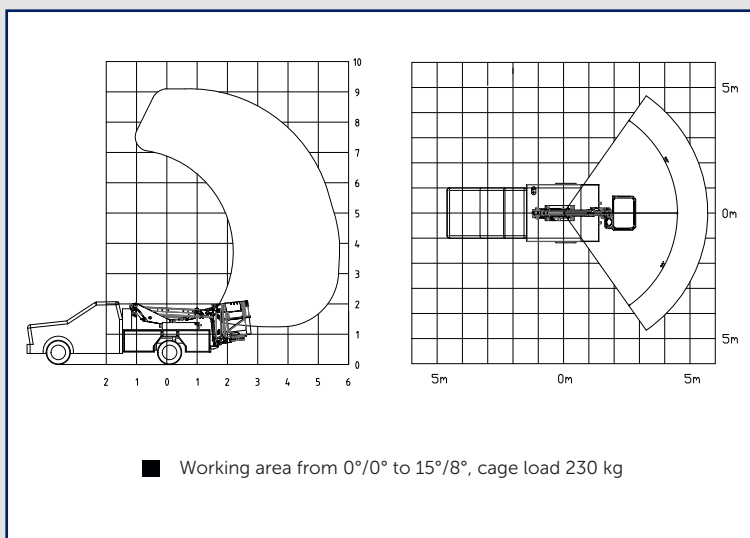

Images



The images in this literature may show options. Danilift A/S reserves the right to change technical information without notice.